

How Is TB Transmitted ?

Sébastien Gagneux, PhD

20th March, 2008

Today's Outline

- 1) Global spread of *Mtb*
 - Comparative genomics
 - Phylogeny

- 2) Transmission of drug-resistant *Mtb*
 - Fitness assays
 - Molecular epidemiology

The Global Diversity of *Mtb*

Global strain collection:
875 strains
80 countries



Large Sequence Polymorphisms

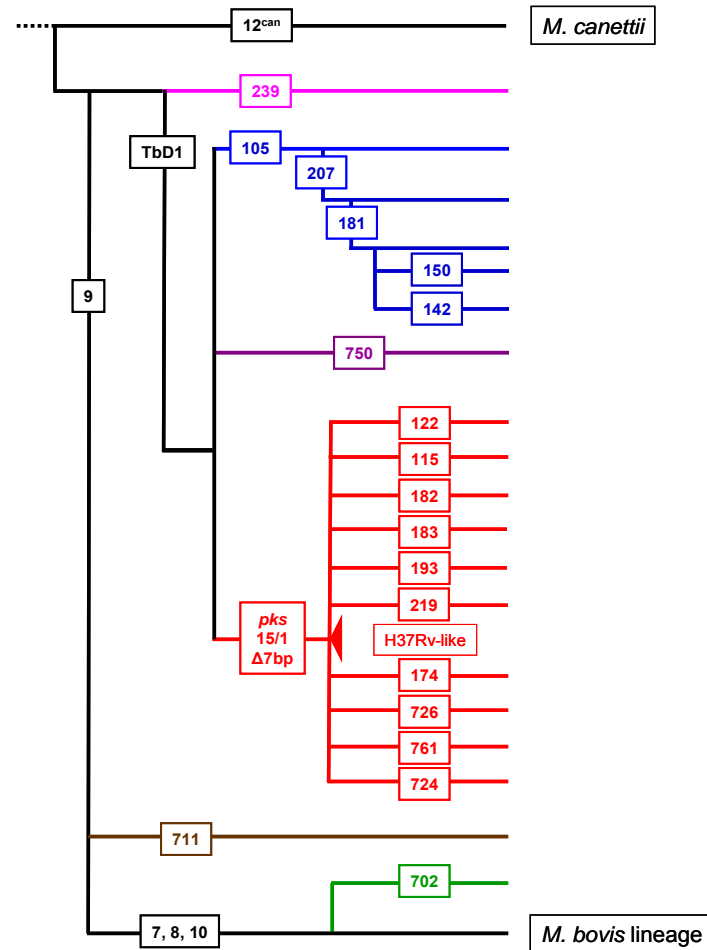

Gagneux et al. *PNAS* 2006

Geographic Distribution of *Mtb* Diversity

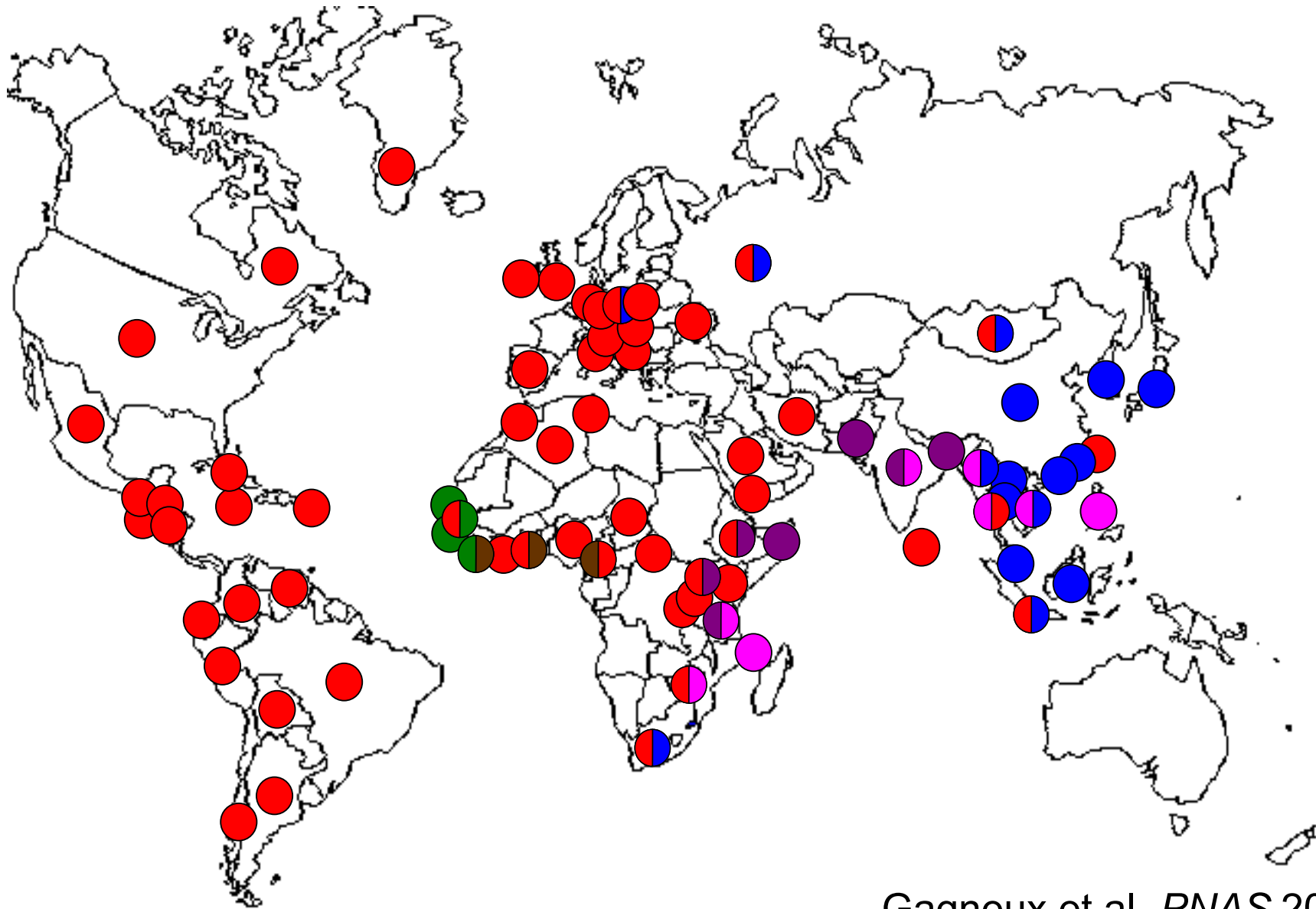

Gagneux et al. *PNAS* 2006

Global TB Burden by *Mtb* Lineage

Estimated number of prevalent cases in 2003 (WHO 2005)

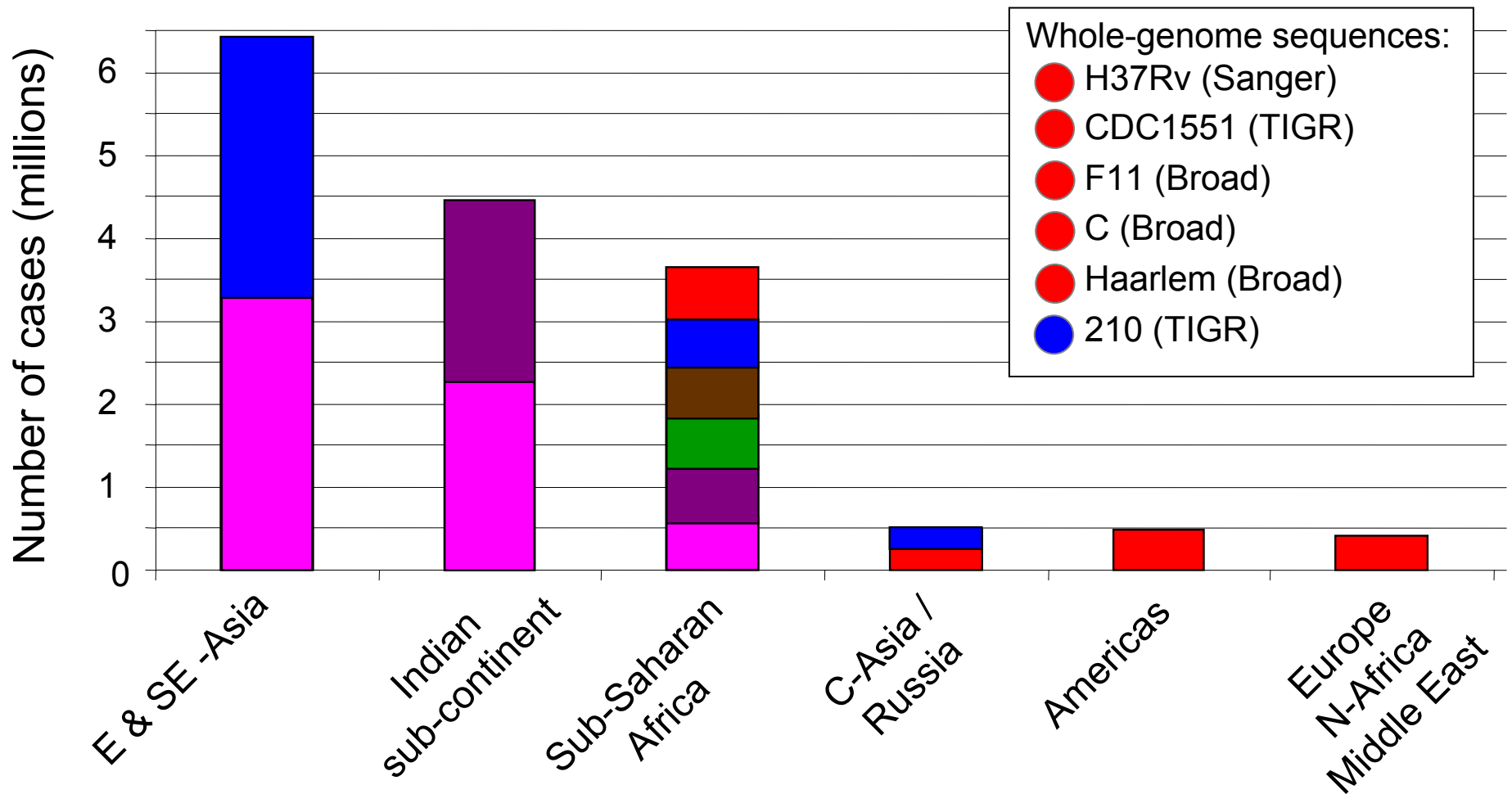

Global Phylogeny of *M. tuberculosis*

- 108 strains
- ~70kbp/strain

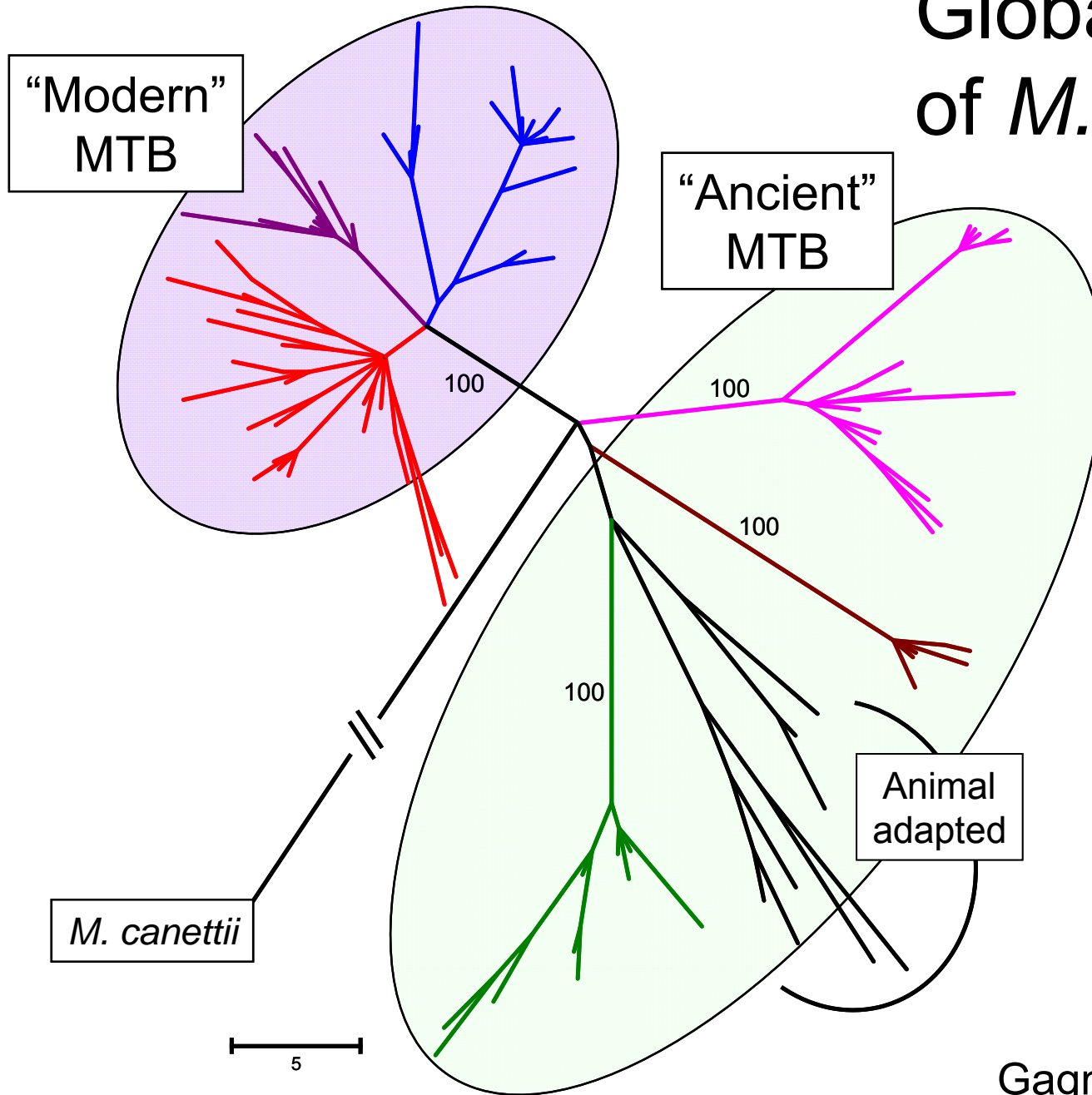

Gagneux et al. *in preparation*

“Out-of-Africa” of *M. tuberculosis* ?

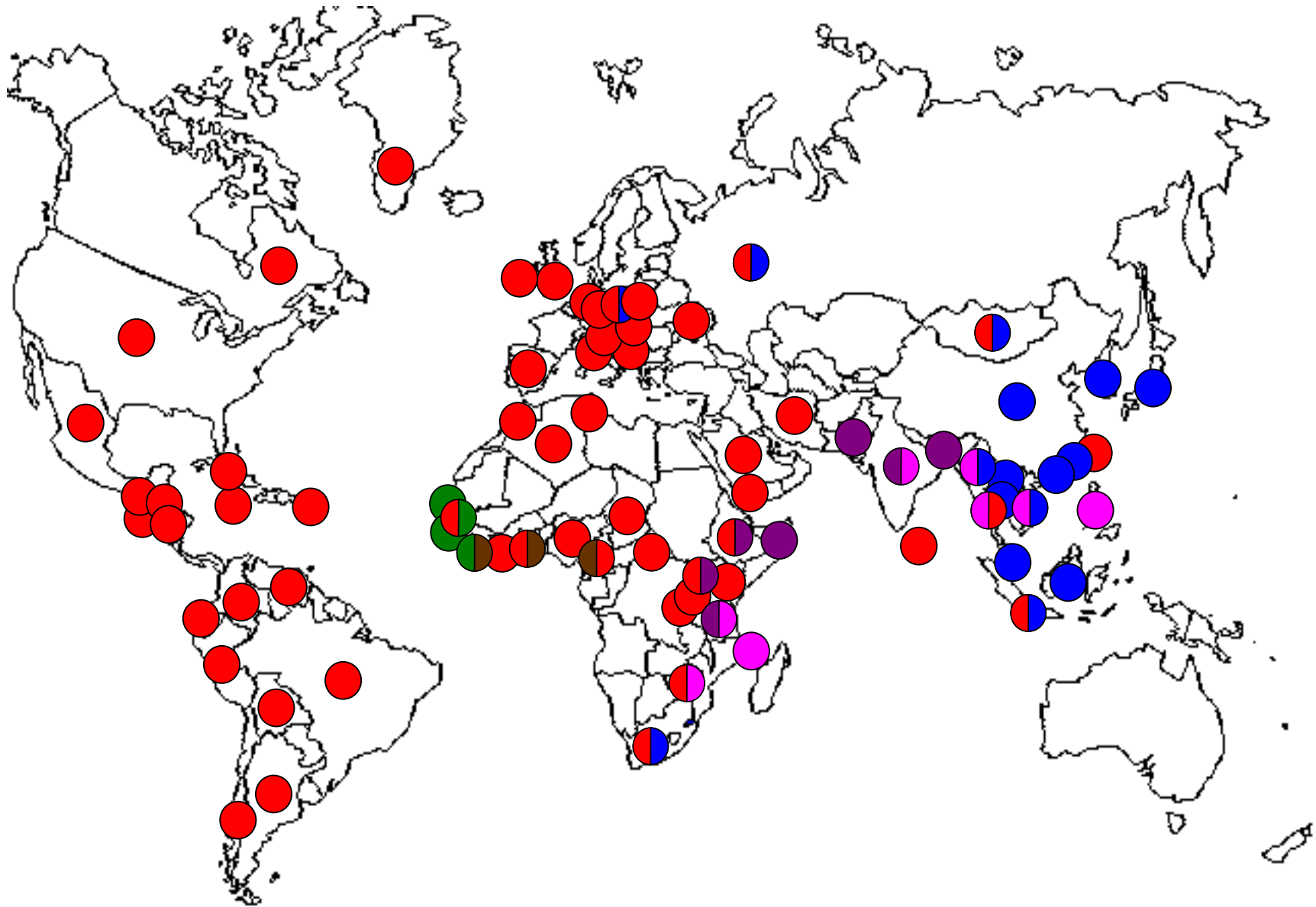

1) Global Spread of *Mtb*: Conclusions

- Origin of *Mtb* most likely in Africa
- Geographical distribution of *Mtb* diversity suggests “Out-of-Africa”...But!
- More recent migration also involved (travel, trade, conquest)
- Different evolutionary histories might have resulted in lineage-specific phenotypic differences (vaccines!).

Where Is TB Now?

Global TB 2005 Estimates

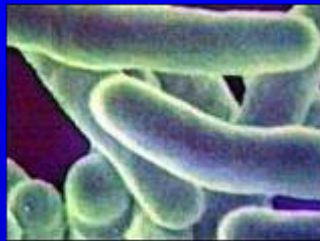

All forms of TB

Estimated
number of
cases

8.8 million

Estimated
number of
deaths

1.6 million

MDR-TB

424,000

116,000

XDR-TB

27,000

16,000

>50% Mortality → Entering post-antibiotic era!

Countries with confirmed XDR-TB



WHO

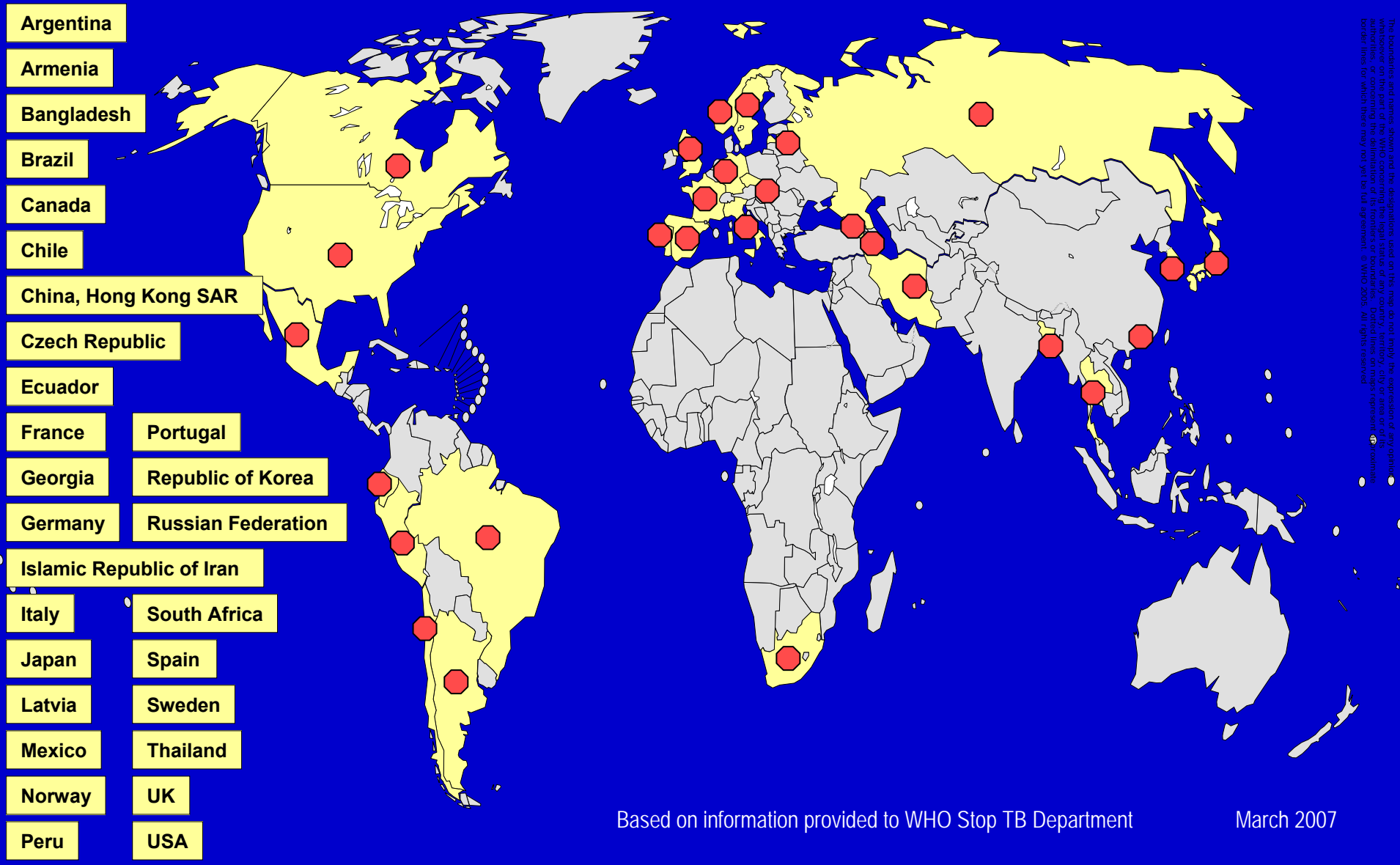

The boundaries and names shown and the designations used on this map do not imply the expression of any opinion of the WHO concerning the delimitation of its frontiers or boundaries. Dotted lines on maps represent approximate border lines for which there may not yet be full agreement. © WHO 2006. All rights reserved.

Based on information provided to WHO Stop TB Department

March 2007

XDR-TB in the **B B C** NEWS

Last Updated: Tuesday, 29 May 2007, 20:48 GMT 21:48 UK

 [E-mail this to a friend](#)

 [Printable version](#)

US in TB flight infection warning

US health officials have quarantined a man who may have exposed passengers on board two trans-Atlantic flights to a dangerous form of tuberculosis.

Officials say crew and passengers on the same flights, from Atlanta to Paris

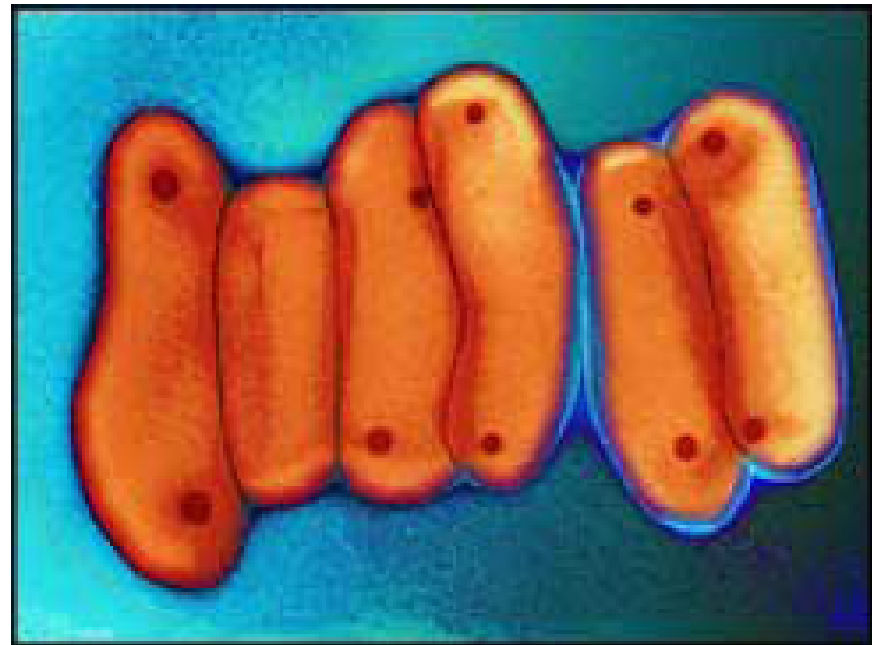

Tuberculosis is a bacterial infection spread through the air

2) Transmission of Drug-resistant *Mtb*

- Public Health is important
- What about Biology ?
- Is drug-resistance costly (to the bug) ?
- Studies in *E. coli* suggest “fitness cost”
- MDR / XDR-TB associated with HIV
- Are XDR strains less “fit” ?

Fitness: The Experimental Approach

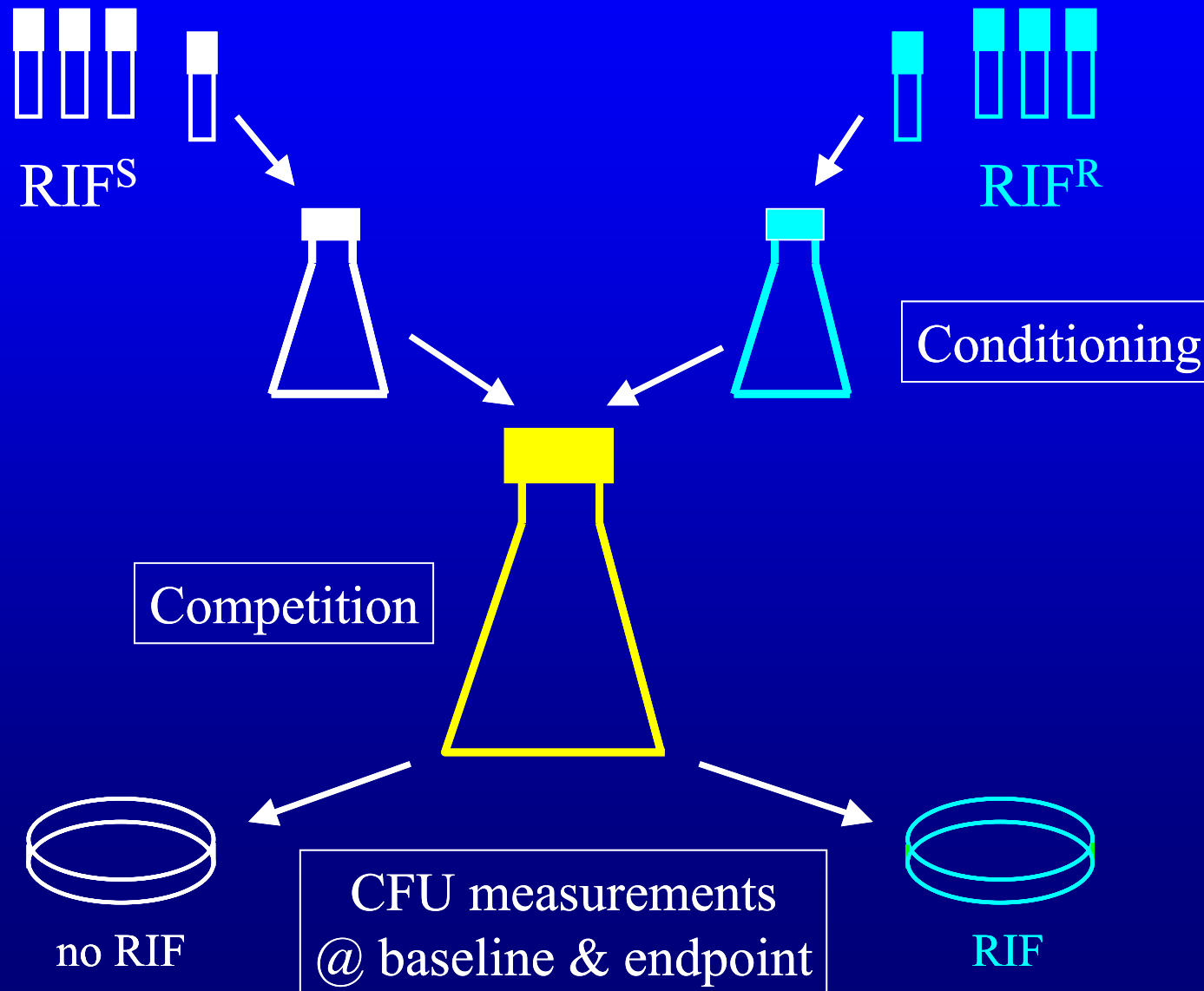

1st strain background: CDC1551

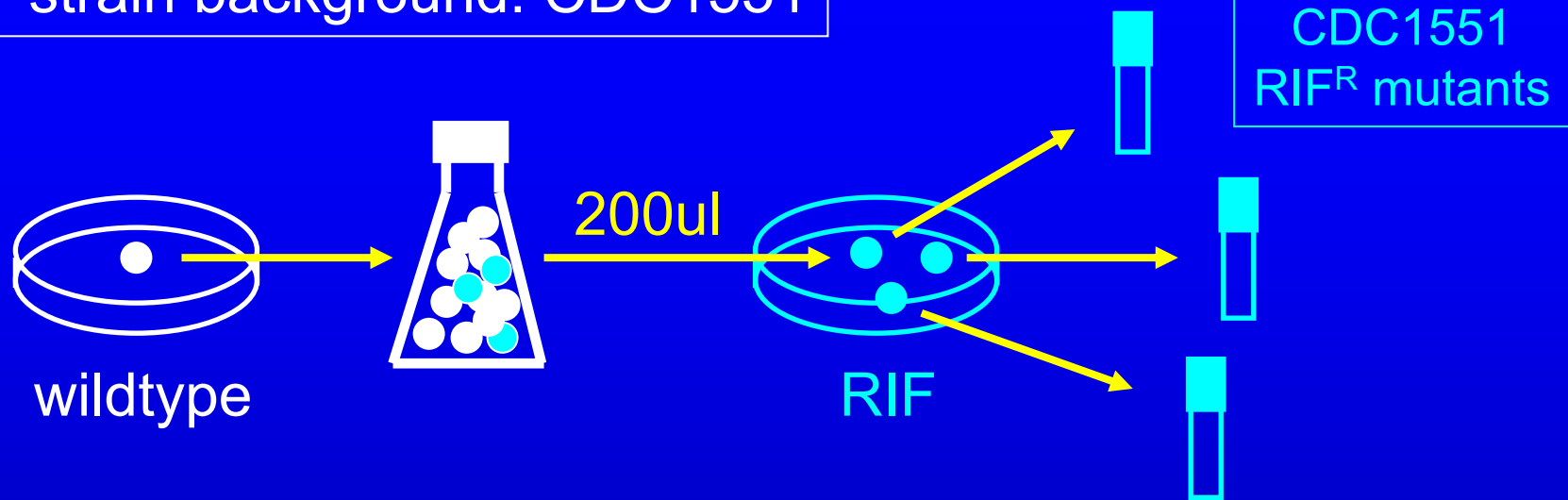

2nd strain background: T85/Beijing

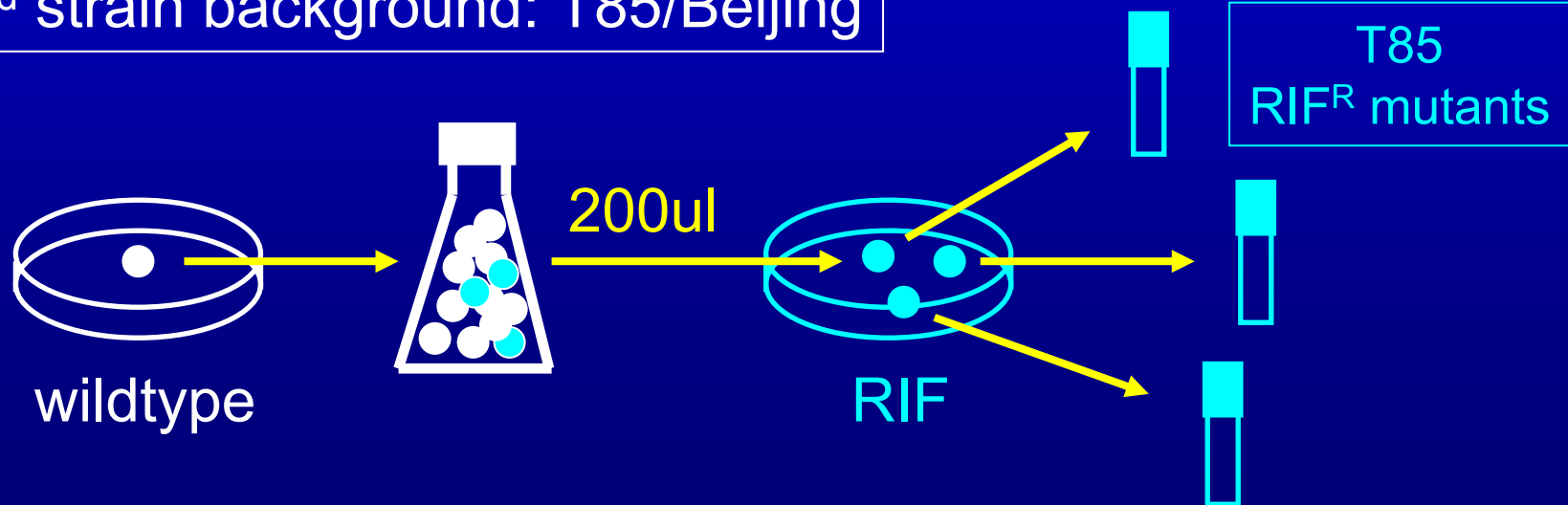

Clinical Isolates with Acquired RIF^R



Fitness Cost of Rifampicin-Resistant *Mtb*

Lab-derived mutants:

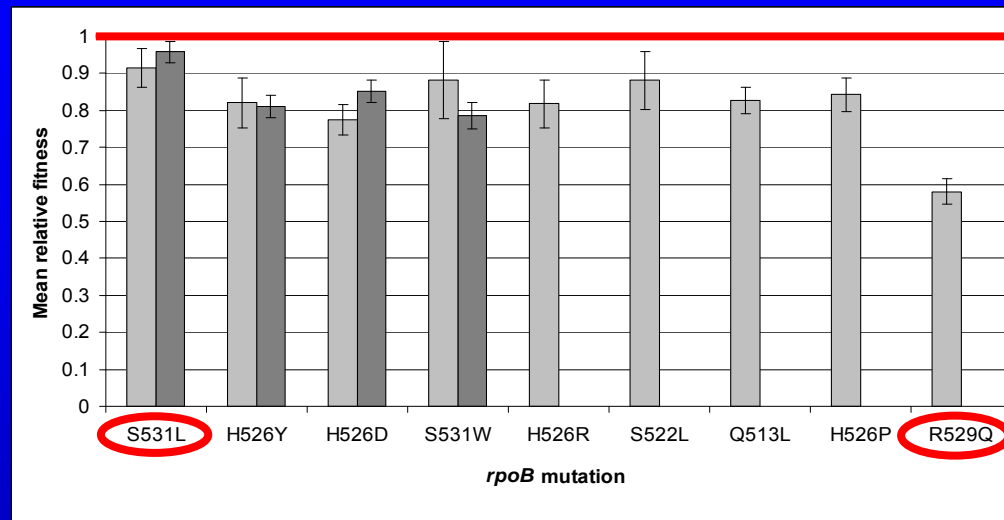

Clinical strains:

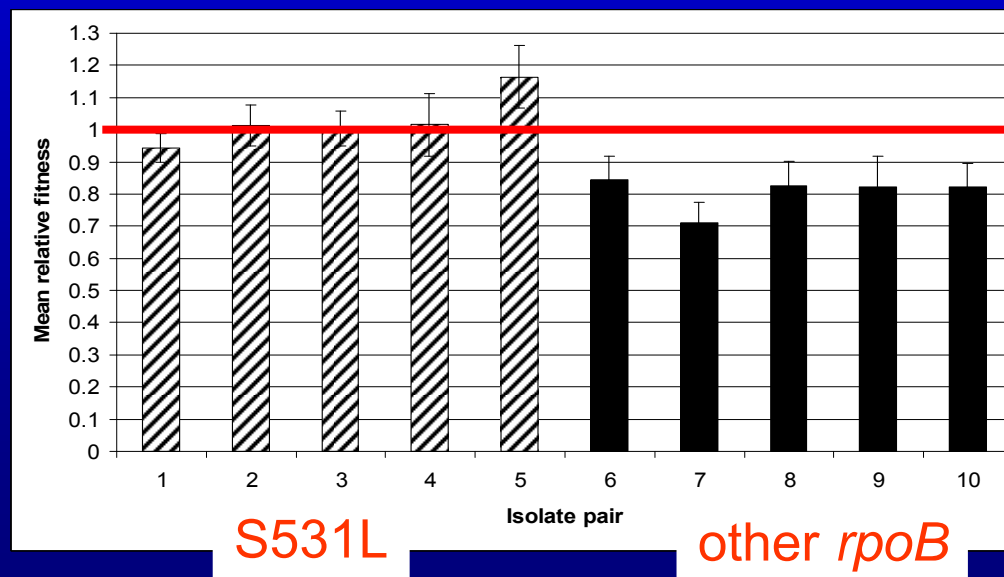

Clinical Frequency of *rpoB* Mutations

<i>rpoB</i> mutation	Mean fitness	Clinical frequency (%)*
S531L	1.02	54
H526Y	0.82	11
H526D	0.78	7
S531W	0.82	4
H526R	0.82	3
R529Q	0.58	0

* based on 840 clinical isolates (O'Sullivan et al. 2005)

Fitness: The Molecular Epidemiology Approach

DNA “fingerprinting” (IS6110 RFLP)

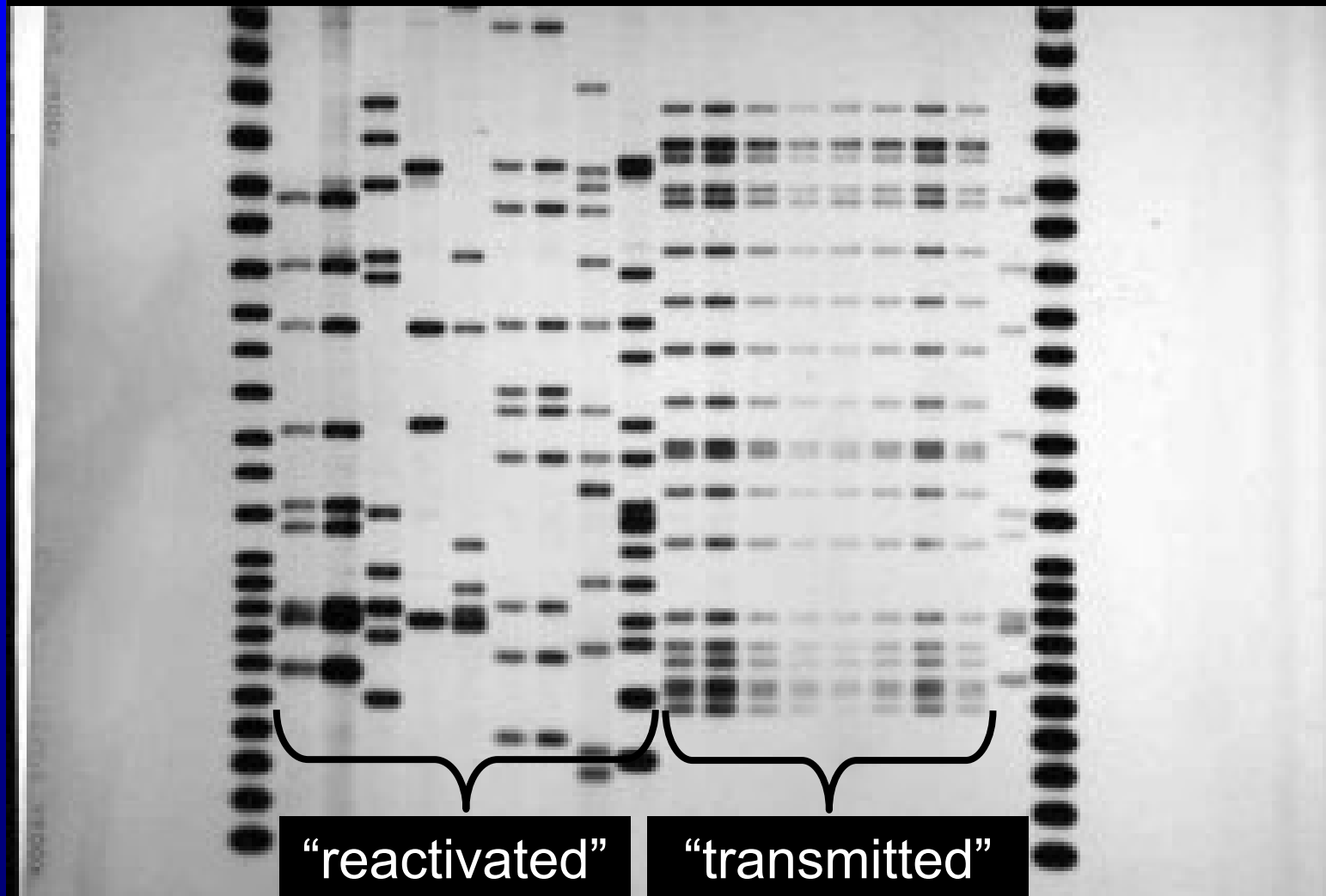

Population-based Molecular Epidemiological Study in San Francisco

- INH resistance caused by different mutations
- Different INH^R mutations have different effects on bacterial virulence / fitness in animal models
- *katG* activates INH and is important for virulence
- Hypothesis:
 - Mutants with high fitness cost will transmit less

Mutations in 152 INH^R Isolates from SF (1991-1999)

Mutation	N	(%)	KatG activity
1) Non-functional KatG	34	(22.4)	- -
2) <i>katG</i> S315T	62	(40.8)	- +
3) <i>inhA</i> prom. -15 c→t	39	(25.7)	+ +
No mutation	17	(11.1)	+ +

INH^R Mutation and RFLP Clustering

Mutation	KatG activity	% RFLP clustering	p-value
1) Non-functional KatG	- -	0.0	reference
2) <i>katG</i> S315T	- +	11.3	< 0.05
3) <i>inhA</i> -15 c→t	+ +	17.8	< 0.01

The Biogeography of *Mtb*

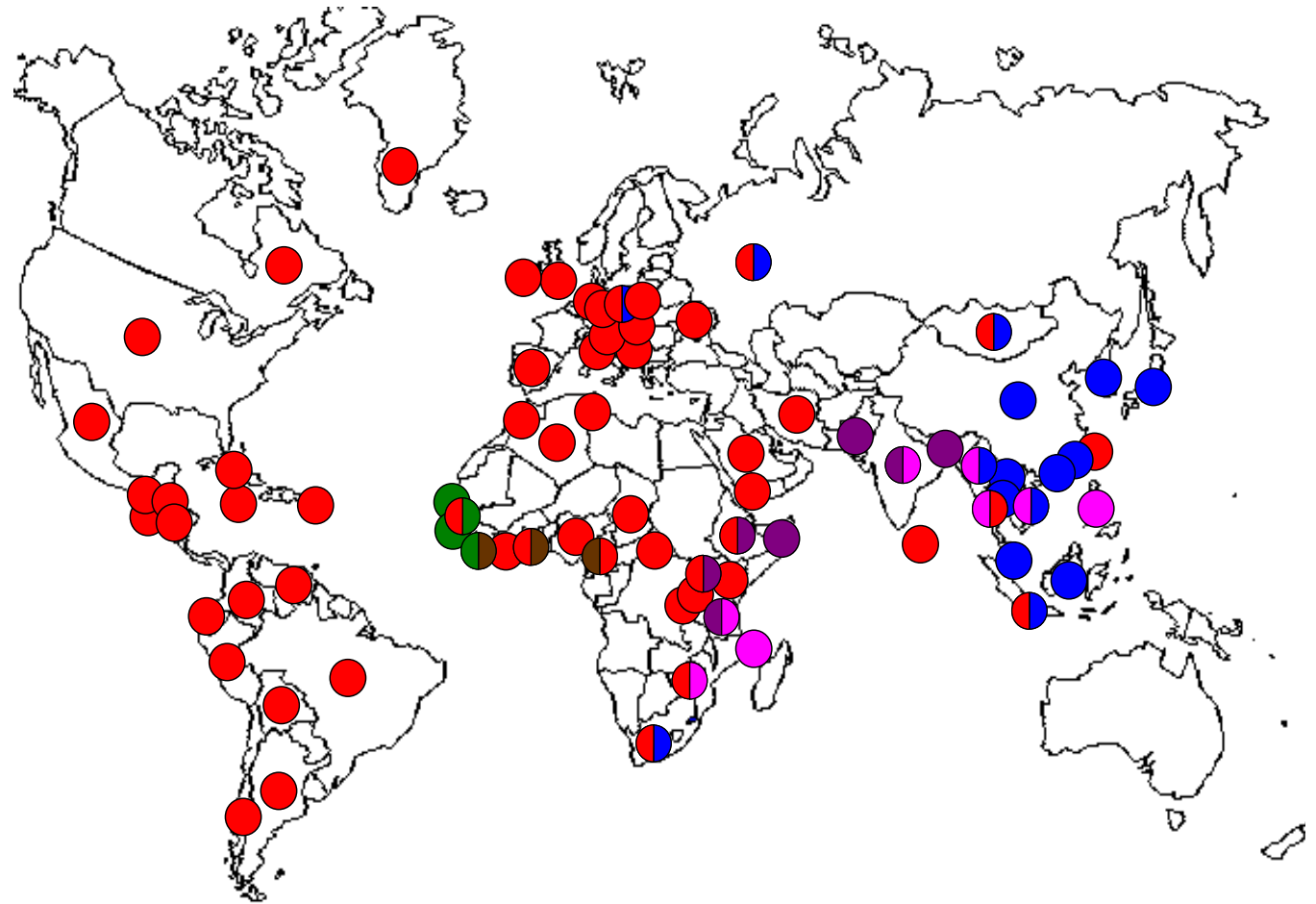
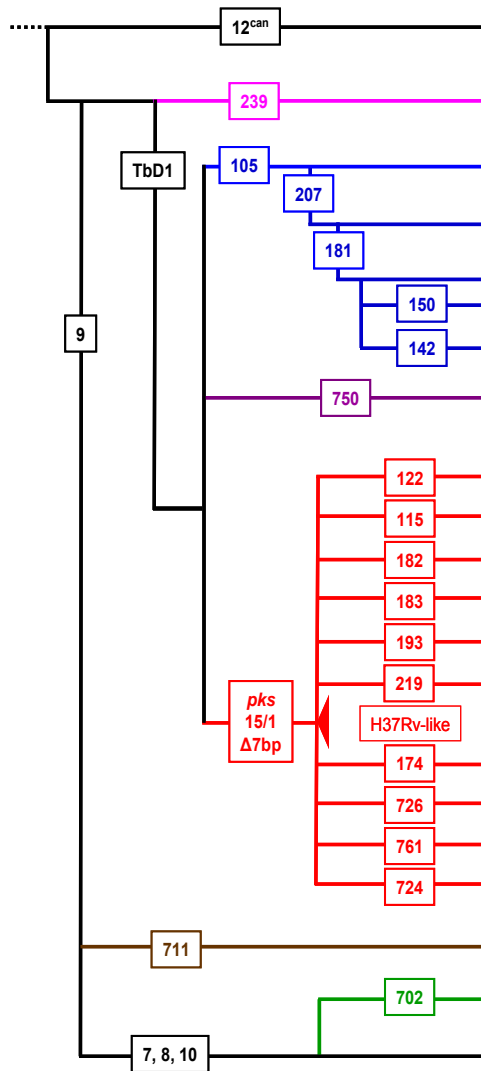

Gagneux et al. *PNAS* 2006

Does Strain Lineage Impact Propensity Towards Low / High-Cost INH^R Mutations ?

Lineage / Mutation	Odds Ratio	P-value
<u>Blue Lineage:</u>		
1) Non-functional <i>katG</i> mutations	5.6	< 0.001
<u>Red Lineage:</u>		
2) <i>katG</i> S315T	2.0	0.052
<u>Pink Lineage:</u>		
3) <i>inhA</i> prom. -15 c→t	3.8	< 0.001

Blue *Mtb* (Beijing) Associated with MDR

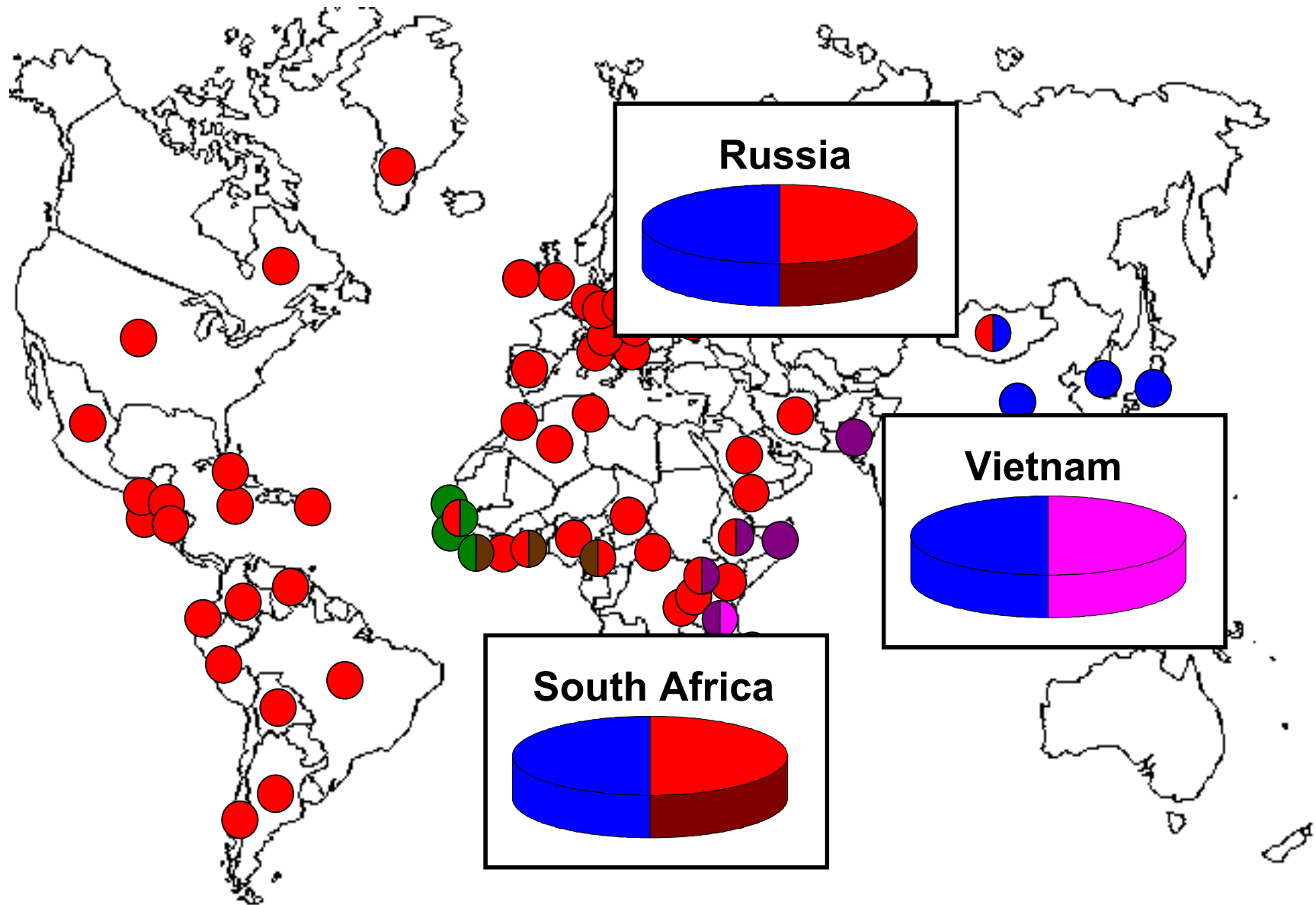

2) Transmission of Drug-resistant *Mtb*: Conclusions

- Fitness and transmission of drug-resistant *Mtb* is a function of:
 - Specific mutation
 - Strain genetic background
 - Compensatory evolution (?)
- Implications for predicting the future of MDR / XDR-TB

Evolution of Drug Resistance

- No-cost mutation
- Pre-adapted genetic background

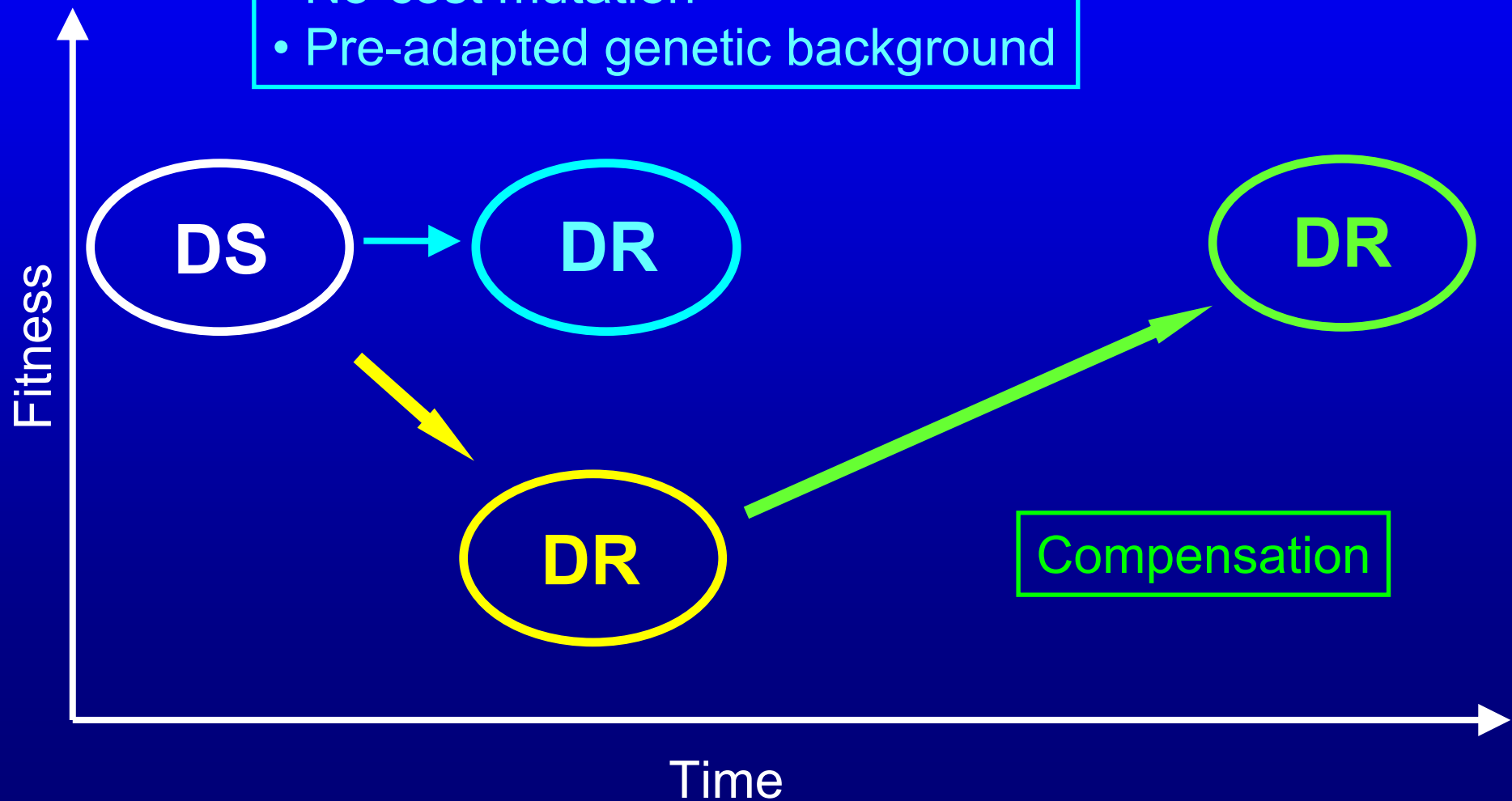

Acknowledgments

ISB, Seattle

- Peter Small
- Hadar Sheffer
- Lee Rowen
- Jared Roach
- Marta Janer
- Scott Bloom

NIMR, London

- Douglas Young
- Vivek Rao
- Damien Portevin

Stanford

- Marcus Feldman
- Misha Lipatov
- Dmitri Petrov
- Ruth Hershberg
- Brendan Bohannan
- Alex Pym
- Clara Davis Long
- Gary Schoolnik
- Tran Van

UC San Francisco

- Phil Hopewell
- Midori Kato-Maeda

Funding:

- Swiss National Science Foundation
- Novartis Foundation
- National Institutes of Health
- Wellcome Trust